

FT12-155Ah

Valve-regulated lead-acid battery



FRONT TERMINAL SERIES

Characteristics

Nominal voltage	12V (6 cells per unit)	
Nominal capacity at 10 hours rate/10.8V (25°C)	155Ah	
Capacity (25°C)	20 Hours rate/10.8V	164.4Ah
	5 Hours rate/10.8V	132.5Ah
Terminal type	T18	
Torque	12.3±2.5N.m	
Approx. internal resistance (25°C)	4.0 mΩ	
Dimensions	Length	546±2mm (21.50inch)
	Width	125±2mm (4.92inch)
	Height	315±2mm (12.40inch)
	Total height	315±2mm (12.40inch)
Design Life (stand-by)	JIS at 25°C	12 years
	Eurobat at 20°C	10/12 years
Weight	50.00kg (110.23lbs)±3%	
Nominal operating temperature	25°C±3 (77±5°F)	
Operating temperature range	Discharge	-15°C~50°C (5°F~122°F)
	Charge	-10°C~50°C (14°F~122°F)
	Storage	-20°C~50°C (-4°F~122°F)
Float charging voltage at 25°C	13.5V~13.8V	
Cyclic charging voltage at 25°C	14.5V~15.0V	
Temperature compensation	Float charge	-18mV/°C/Block
	Cycle charge	-30mV/°C/Block
Max. charging current (A)	46A	
Max. discharge current for 5 seconds	1100A	
Self discharge rate (25°C)	≤3%/month	
Battery container ABS UL94-HB	V-0 optional	

Overview

NPP Power Front Terminal Series batteries are mainly used in the area of communication. By adopting a new AGM separator and centralized venting system, the battery can be installed in different positions while maintaining high reliability. Available in gel technology also.

Dimensions & Terminal Type (mm)

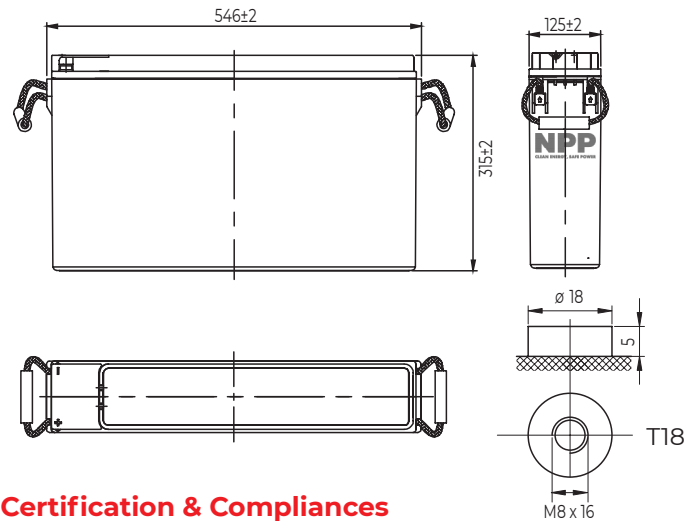

Certification & Compliances



Compliant to: EUROBAT, RoHS, WEEE's and Reach.
Manufactured according to IEC 60896-21 / 22

Construction

Component	Positive Plate	Negative plate	Container	Separator	Electrolyte	Safety valve	Terminal
Raw material	Lead dioxide	Lead	ABS (V-0 opt.)	AGM	Sulfuric Acid	Rubber	Copper

Constant current discharge characteristics at 25°C

(Ampere/battery)

F.V/Time	15min	30min	60min	2h	3h	4h	5h	6h	8h	10h	20h
9.60V	255	153	93.9	56.6	40.8	32.6	27.8	24.2	19.1	15.8	8.36
9.90V	249	150	92.5	56.3	40.5	32.4	27.7	24.0	19.0	15.7	8.35
10.2V	240	145	90.1	55.8	40.3	32.2	27.5	23.9	18.9	15.7	8.32
10.5V	232	142	87.3	55.0	40.0	31.9	27.3	23.7	18.8	15.6	8.27
10.8V	219	136	84.5	53.6	38.8	31.0	26.5	23.0	18.2	15.5	8.22

Constant power discharge characteristics at 25°C

(Watts/battery)

F.V/Time	15min	30min	60min	2h	3h	4h	5h	6h	8h	10h	20h
9.60V	2802	1713	1070	656	480	383	329	286	227	188	100
9.90V	2735	1679	1054	652	477	381	327	284	226	188	100
10.2V	2634	1627	1027	646	474	378	325	282	224	187	99.9
10.5V	2544	1588	995	636	470	375	322	280	223	186	99.3
10.8V	2410	1530	963	620	456	364	313	272	216	185	98.6

The above characteristics represent average values and can be obtained within three charge and discharge cycles. The batteries must be fully charged before testing. The data in this document is subject to change without notice and become contractual only after written confirmation. Please contact NPP Power for the latest available version.

NPP Power (Vietnam) Co.,Ltd

Lot A22.3, Road C4, Thanh Thanh Cong Industrial Zone,
An Hoa Village, Trang Bang District, Tay Ninh Province,
Vietnam

Guangzhou NPP Power Co, Ltd.

No.67 Lianglong Road, Huashan Town, Huadu District,
Guangzhou, China
Email: info@nppower.com.cn Tel. +86 20 37887 390