

FTG12-125Ah

Valve-regulated lead-acid battery



FRONT TERMINAL SERIES

Characteristics

Nominal voltage	12V (6 cells per unit)	
Nominal capacity at 10 hours rate/10.8V (25°C)	125Ah	
Capacity (25°C)	20 Hours rate/10.8V	132.6 Ah
	5 Hours rate/10.8V	103 Ah
Terminal type	T18	
Torque	12.3±2.5N.m	
Approx. internal resistance (25°C)	5.0 mΩ	
Dimensions	Length	550±2mm (21.70inch)
	Width	105±2mm (4.13inch)
	Height	315±2mm (12.40inch)
	Total height	315±2mm (12.40inch)
Design Life (stand-by)	JIS at 25°C	12 years
	Eurobat at 20°C	10/12 years
Weight	42.00kg (92.59lbs)±3%	
Nominal operating temperature	25°C±3 (77±5°F)	
Operating temperature range	Discharge	-15°C~50°C (5°F~122°F)
	Charge	-10°C~50°C (14°F~122°F)
	Storage	-20°C~50°C (-4°F~122°F)
Float charging voltage at 25°C	13.5V~13.8V	
Cyclic charging voltage at 25°C	14.4V~14.7V	
Temperature compensation	Float charge	-18mV/°C/Block
	Cycle charge	-30mV/°C/Block
Max. charging current (A)	25A	
Max. discharge current for 5 seconds	900A	
Self discharge rate (25°C)	≤3%/month	
Battery container ABS UL94-HB	V-0 optional	

Overview

NPP Power Front Terminal Series batteries are mainly used in the area of communication. By adopting a new AGM separator and centralized venting system, the battery can be installed in different positions while maintaining high reliability. Available in gel technology also.

Dimensions & Terminal Type (mm)

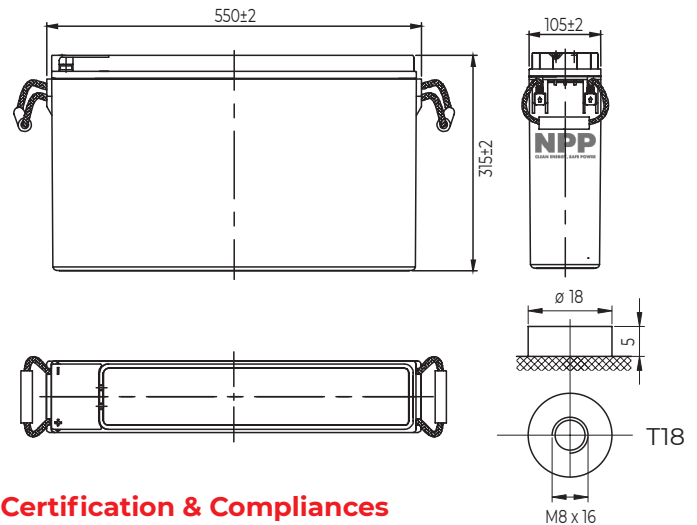

Certification & Compliances



Compliant to: EUROBAT, RoHS, WEEE's and Reach.
Manufactured according to IEC 60896-21 / 22

Construction

Component	Positive Plate	Negative plate	Container	Separator	Electrolyte	Safety valve	Terminal
Raw material	Lead dioxide	Lead	ABS (V-0 opt.)	AGM	Sulfuric Acid Gel	Rubber	Copper

Constant current discharge characteristics at 25°C

(Ampere/battery)

F.V/Time	15min	30min	60min	2h	3h	4h	5h	6h	8h	10h	20h
9.60V	196	119	73.5	45.7	32.5	25.5	21.7	19.1	15.3	12.7	6.74
9.90V	191	116	72.4	45.4	32.3	25.4	21.5	19.0	15.2	12.7	6.73
10.2V	184	113	70.6	45.0	32.1	25.2	21.4	18.9	15.1	12.7	6.71
10.5V	178	110	68.4	44.3	31.9	25.0	21.3	18.8	15.0	12.6	6.67
10.8V	169	106	66.2	43.2	31.2	24.3	20.6	18.2	14.6	12.5	6.63

Constant power discharge characteristics at 25°C

(Watts/battery)

F.V/Time	15min	30min	60min	2h	3h	4h	5h	6h	8h	10h	20h
9.60V	2152	1333	838	529	382	300	256	226	182	152	80.9
9.90V	2100	1307	825	526	380	298	255	225	181	152	80.8
10.2V	2023	1267	804	521	377	296	253	223	179	151	80.5
10.5V	1954	1236	779	513	375	294	251	222	178	150	80.1
10.8V	1851	1191	754	500	367	285	244	215	173	149	79.5

The above characteristics represent average values and can be obtained within three charge and discharge cycles. The batteries must be fully charged before testing. The data in this document is subject to change without notice and become contractual only after written confirmation. Please contact NPP Power for the latest available version.

NPP Power (Vietnam) Co.,Ltd

Lot A22.3, Road C4, Thanh Thanh Cong Industrial Zone,
An Hoa Village, Trang Bang District, Tay Ninh Province,
Vietnam

Guangzhou NPP Power Co, Ltd.

No.67 Lianglong Road, Huashan Town, Huadu District,
Guangzhou, China
Email: info@nppower.com.cn Tel. +86 20 37887 390