

# NPD12-200Ah

Valve-regulated lead-acid battery



# DEEP CYCLE SERIES

## Characteristics

Nominal voltage	12V (6 cell per unit)	
Nominal capacity at 10 hours rate/10.8V (25°C)	204Ah	
Capacity (25°C)	20 Hours rate/10.8V	216Ah
	5 Hours rate/10.8V	174Ah
Terminal type	T16	
Torque	12.3±2.5N.m	
Approx. internal resistance (25°C)	3 mΩ	
Dimensions	Length	522±2mm (20.55inch)
	Width	238±2mm (9.37inch)
	Height	218±2mm (8.58inch)
	Total height	222±2mm (8.74inch)
Design Life (stand-by)	JIS at 25°C	10 years
	Eurobat at 20°C	10/12 years
Weight	62.50kg (137.80lbs)±3%	
Nominal operating temperature	25°C±3 (77±5°F)	
Operating temperature range	Discharge	-15°C~50°C (5°F~122°F)
	Charge	-10°C~50°C (14°F~122°F)
	Storage	-20°C~50°C (-4°F~122°F)
Float charging voltage at 25°C	13.5V~13.8V	
Cyclic charging voltage at 25°C	14.5V~15.0V	
Temperature compensation	Float charge	-18 mV/°C/Block
	Cycle charge	-30 mV/°C/Block
Max. charging current (A)	60.0A	
Max. discharge current for 5 seconds	1400A	
Self discharge rate (25°C)	≤3%/month	
Battery container ABS UL94-HB	V-0 optional	

## Overview

NPP Power Deep Cycle Series are manufactured specifically to provide outstanding performance in deep cycling applications. The batteries are designed using enhanced alloy contents plates and active paste materials.

## Dimensions & Terminal Type (mm)

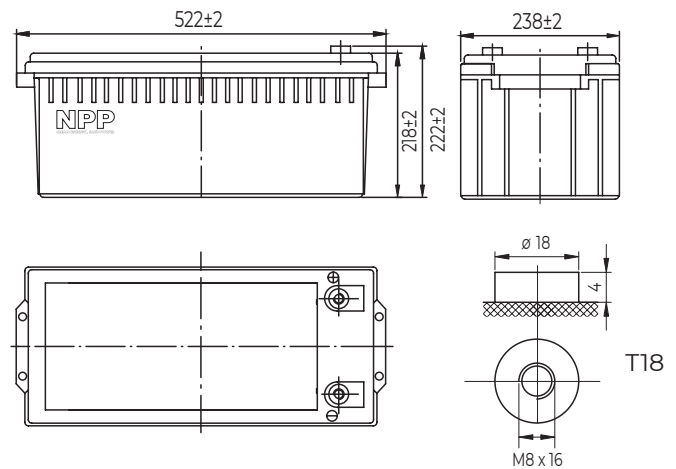

## Certification & Compliances



Compliant to: EUROBAT, RoHS, WEEE's and Reach.  
Manufactured according to IEC 60896-21 / 22

## Construction

Component	Positive Plate	Negative plate	Container	Separator	Electrolyte	Safety valve	Terminal
Raw material	Lead dioxide	Lead	ABS (V-0 opt.)	AGM	Sulfuric Acid	Rubber	Copper

## Constant current discharge characteristics at 25°C

(Ampere/battery)

F.V/Time	15min	30min	60min	2h	3h	4h	5h	6h	8h	10h	20h
9.60V	343	205	126	74.5	53.7	42.9	36.6	31.8	25.2	20.8	11.0
9.90V	334	201	124	74.1	53.4	42.6	36.4	31.6	25.0	20.7	11.0
10.2V	322	195	121	73.4	53.0	42.3	36.2	31.4	24.9	20.7	11.0
10.5V	311	190	117	72.3	52.6	42.0	35.9	31.2	24.7	20.5	10.9
10.8V	295	183	113	70.5	51.1	40.8	34.8	30.3	23.9	20.4	10.8

## Constant power discharge characteristics at 25°C

(Watts/battery)

F.V/Time	15min	30min	60min	2h	3h	4h	5h	6h	8h	10h	20h
9.60V	3763	2300	1437	863	631	504	433	376	299	248	132
9.90V	3673	2254	1416	858	628	501	430	374	297	247	132
10.2V	3537	2185	1380	850	623	498	427	372	295	247	131
10.5V	3417	2132	1337	838	619	494	424	369	293	245	131
10.8V	3236	2054	1293	816	600	479	412	358	284	244	130

The above characteristics represent average values and can be obtained within three charge and discharge cycles. The batteries must be fully charged before testing. The data in this document is subject to change without notice and become contractual only after written confirmation. Please contact NPP Power for the latest available version.

### NPP Power (Vietnam) Co.,Ltd

Lot A22.3, Road C4, Thanh Thanh Cong Industrial Zone,  
An Hoa Village, Trang Bang District, Tay Ninh Province,  
Vietnam

### Guangzhou NPP Power Co, Ltd.

No.67 Lianglong Road, Huashan Town, Huadu District,  
Guangzhou, China  
Email: info@nppower.com.cn Tel. +86 20 37887 390